

ALAD-A1010T/T(P)

10.1" TFT LCD Capacitive/Resistive Touch, Intel® Elkhart lake Soc CPU, 2*COM, 2*LAN, 4*USB3.1, 1* Line out, 1*2.5" SATA bay, 1*mSATA, DC 9~36V

JHCTECH IoT Computer Connecting the Dots

Industrial Panel Computer
ALAD Series

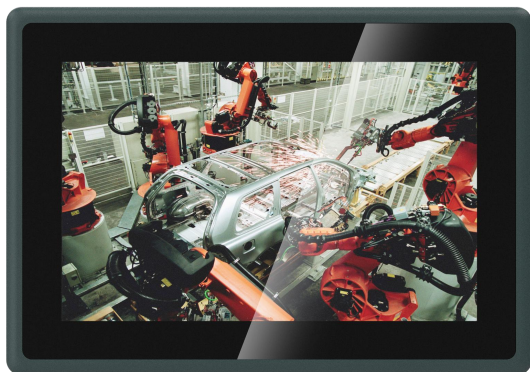

Key Features

- Aluminum die-casting chassis
- 10.1" TFT LCD, Multi-point capacitive/5 wire resistive touch
- Intel® Elkhart lake Soc CPU, fanless design
- 1*DDR4 3200 SODIMM, up to 32GB
- 1*Mini PCIe, 1*M.2 B-Key Type 3042/3052
- 2*COM, 2*LAN, 4*USB3.1, 1*8-bit DIO (Optional with COM1/2)
- 2.5" SATA Bay, 1*mSATA, 1*Line out, 2*2W Speaker
- DC 9~36V power input
- IP65 rated front panel protection
- Standard VESA mount and panel mounting

Description

ALAD-A1010T/T(P) is a full flat mirror panel powered by an Intel® Elkhart lake Soc CPU series processor. It adopts 10.1" 1280*800 resolution TFT LCD and fully fits surface projection multi-point capacitive/5 wire resistive touch screen. The product has a comprehensive I/O interface, supporting 1*2.5" SATA disk and 1*mSATA dual storage; Built-in 1*Mini PCIe and 1*M.2 3042/3052 expansions, wide voltage DC power supply from 9 to 36V, aluminum die-cast body without fan heat dissipation, various installation modes, suitable for intelligent MES system and device management HMI.

I/O View

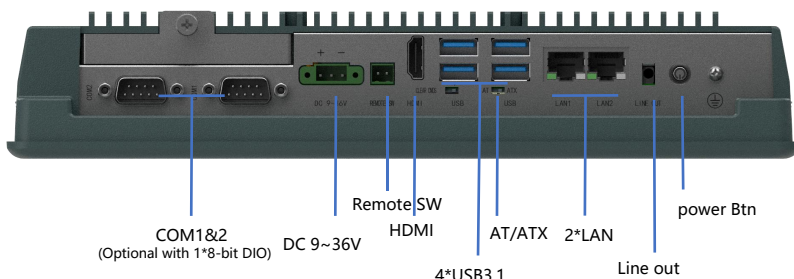

SPEC.

System	CPU	Intel® Elkhart lake SoC CPU: Celeron J6412 2.0-2.6GHz 4-core 4-thread
	Chipset	Intel® CPU SoC MCP
	System memory	1*DDR4 3200 MHz SODIMM, up to 32GB
	BIOS	AMI EFI BIOS, 128Mbit SPI flash memory
	Storage	1*2.5" SATA HDD bay, support SATA3.0 6Gbps HDD/SSD; 1*mSATA
	Display	10.1" 1280*800@60Hz TFT LCD, 1*HDMI for extended display Intel UHD Graphics or iRIS® Xe Graphics, Supports the Intel DL boost deep learning to strengthen technology, DirectX12.1, OpenGL 4.6 and OpenCL 3.0, HDMI Max resolution 4096*2304@60Hz
	Expansion	1*Mini PCIe (PCIe&USB signal), supports a functional module with PCIe or USB signals 1*M.2 B-Key Type 3042/3052 with SIM card slot, supports 4G LTE/5G NR
	Audio	Realtek ALC897 controller, support 5.1 channel, 2*2W Speaker
	Real I/O	2*COM: 2*RS232/422/485; 1*HDMI; 1*Line out; 4*USB3.1 Type A; 2*RJ45 1*3 pin DC-IN terminal pin; 1*Remote SW
	Front panel	IP65 rated
	LAN	2*Intel 210_AT PCIe Gig. Ethernet, 10/100/1000Mbps, support WOL
	Control SW/LED	Power LED, 1*CMOS, 1*AT/ATX, 2-pin terminal remote switch
	Power Supply	DC to DC: 9~36V input, consumption: 25.8W(CPU Celeron J6412 @2.00GHz, 8G DDR4, 128G SSD)
OS	Windows 11*IoT enterprise, Windows 10*IoT enterprise, SUSE, Ubuntu, Wind River, Red Hat*Enterprise, Wind River VxWorks*7, Yocto	
Construction	Aluminum die-casting front bezel, fin-shaped radiator shell	
Mechanical & Environmental	Operating Temperature	-10~60°C (14~140 °F)
	Storage Temperature	-20~70°C (-4~158 °F)
	Storage Humidity	10~95%@40, non-condensing
	Shock	10G peak acceleration(duration 11ms), in operating with HDD
	Vibration	1G 5~500Hz, in operating with HDD
	Mounting	Panel mounting (Cut out: 271*189mm), VESA 75*75mm
	Dimension	(W*H*D): 275*193*51mm
	Net Weight	1.85Kg
EMC	CE,FCC Class A	

LCD	Type	10.1" TFT LED backlight	
	Resolution	1280*800@60Hz	
	Color	16.2M	
	Pixel Pitch(mm)	56.5(H) × RGB × 169.5(V)	
	Brightness(cd/m2)	400	
	Viewing Angle	85°(left), 85°(right), 85°(up), 85°(down)	
	Backlight Lifetime	30000 Hours	
Touch	Type	Projected capacitive touch	5 wire resistive touch
	Surface Hardness	≥6H	≥3H
	Light Transmittance	≥85%	83%
	Interface	USB	USB
	Consumption	+5V @300mA	+5V @ 200mA
	OS	Windows/Linux	Windows, Linux
	Click Lifetime	35 million times	30 million times

Dimension

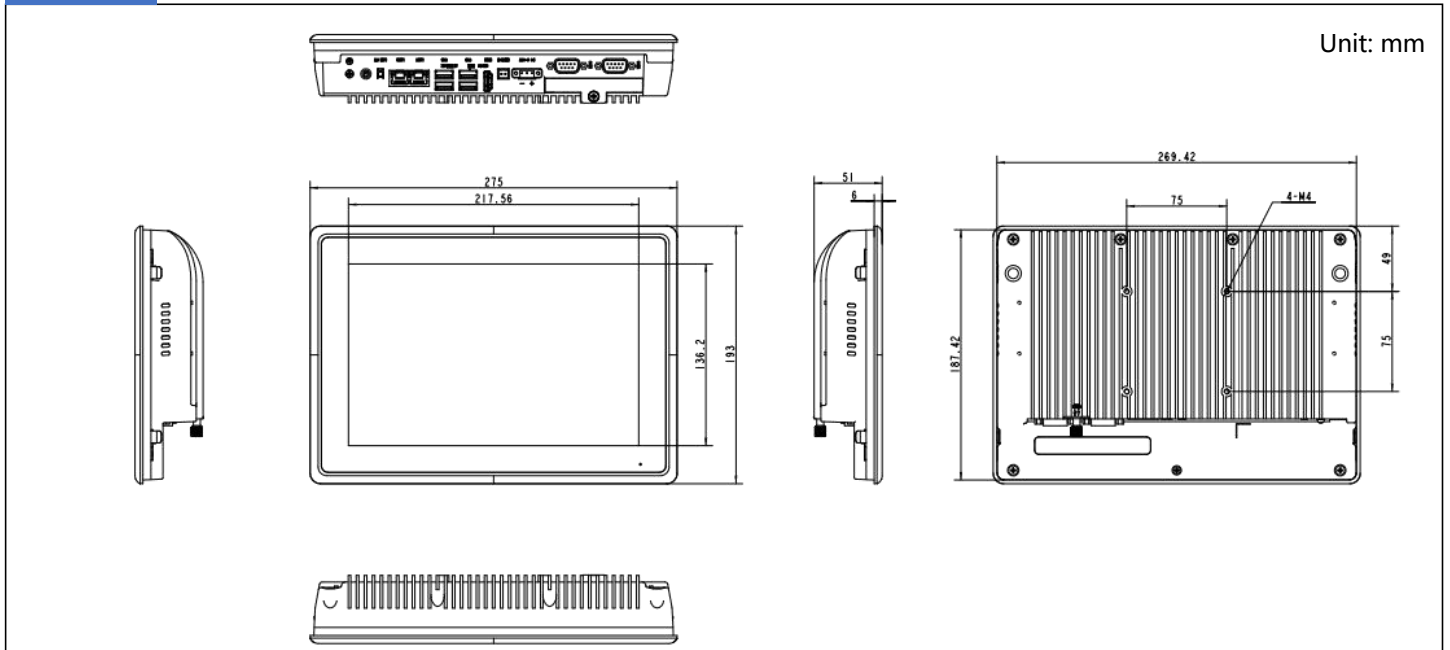

Ordering Info

Model NO.	CPU	TOUCH	Description
ALAD-A1010T/ S001	Celeron J6412	5 wire resistive Touch	Industrial panel computer, 10.1" LCD, 2*COM, 4*USB3.1, 2*LAN, 1*HDMI, 1*Mini PCIe, 1*M.2 B-Key, 1*Line out, 1*2.5" SATA Bay, 1*mSATA, 2*2W Speaker, DC 9~36V power input
ALAD-A1010T(P)/ S001		Projected Capacitive Touch	
PA-60DC12	AC/DC power adapter, DC12V@5A ,60W		